

# ASAHI

## CHECK VALVE

P.147 SWING CHECK VALVE

P.149 WAFER CHECK VALVE

P.151 BALL CHECK VALVE

P.153 TRUE UNION BALL CHECK VALVE

P.155 BALL FOOT VALVE

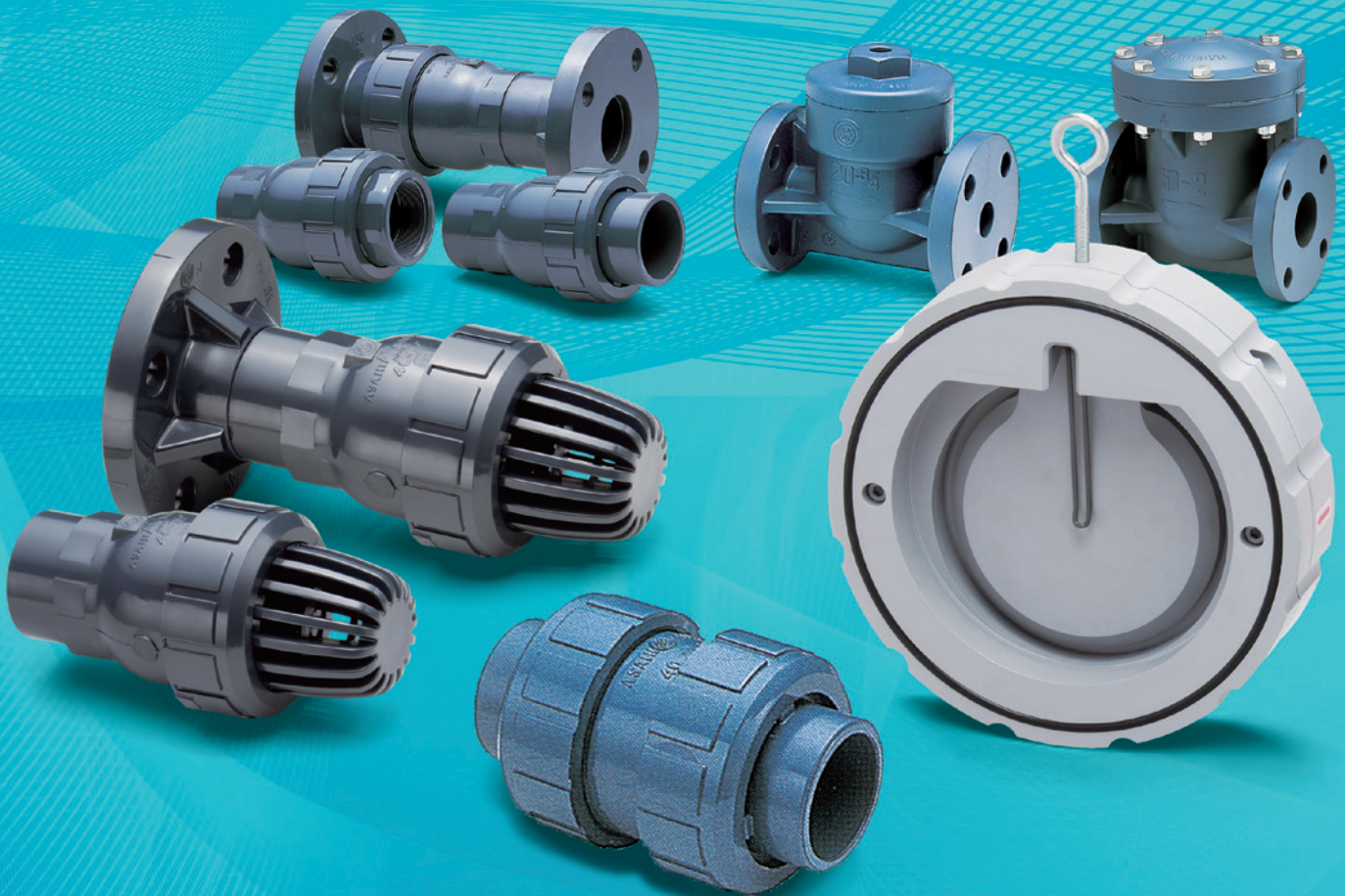

## PERFORMANCE OF SWING CHECK VALVE, BALL CHECK VALVE, AND BALL FOOT VALVE

Min. pressure Unit: kpa {gf/m<sup>2</sup>}, normal temperature

mm	inch		SWING CHECK VALVE				BALL CHECK VALVE, BALL FOOT VALVE			
			VERTICAL PIPING		HORIZONTAL PIPING		VERTICAL PIPING		HORIZONTAL PIPING	
			WHEN FULLY SEALED	WHEN AIR PASSES	WHEN FULLY SEALED	WHEN AIR PASSES	WHEN FULLY SEALED	WHEN AIR PASSES	WHEN FULLY SEALED	WHEN AIR PASSES
15	1/2	EPDM	20 {200}	10 {100}	20 {200}	10 {100}	20 {200}	5 {50}	20 {200}	1 {10}
		PTFE	30 {300}	10 {100}	30 {300}	10 {100}	-	-	-	-
20	3/4	EPDM	20 {200}	10 {100}	20 {200}	10 {100}	30 {300}	5 {50}	30 {300}	1 {10}
		PTFE	35 {350}	10 {100}	35 {350}	10 {100}	-	-	-	-
25	1	EPDM	30 {300}	10 {100}	35 {350}	10 {100}	30 {300}	5 {50}	30 {300}	1 {10}
		PTFE	50 {500}	10 {100}	60 {600}	10 {100}	-	-	-	-
40	1 1/2	EPDM	30 {300}	10 {100}	35 {350}	10 {100}	30 {300}	10 {100}	30 {300}	2 {20}
		PTFE	50 {500}	10 {100}	60 {600}	10 {100}	-	-	-	-
50	2	EPDM	30 {300}	10 {100}	35 {350}	10 {100}	30 {300}	10 {100}	30 {300}	2 {20}
		PTFE	50 {500}	10 {100}	60 {600}	10 {100}	-	-	-	-
65	2 1/2	EPDM	30 {300}	10 {100}	35 {350}	10 {100}	-	-	-	-
		PTFE	50 {500}	10 {100}	60 {600}	10 {100}	-	-	-	-
80	3	EPDM	35 {350}	10 {100}	40 {400}	10 {100}	20 {200}	10 {100}	20 {200}	2 {20}
		PTFE	55 {550}	10 {100}	60 {600}	10 {100}	-	-	-	-
100	4	EPDM	35 {350}	10 {100}	40 {400}	10 {100}	20 {200}	10 {100}	20 {200}	2 {20}
		PTFE	60 {600}	10 {100}	65 {650}	10 {100}	-	-	-	-
125	5	EPDM	35 {350}	10 {100}	40 {400}	10 {100}	-	-	-	-
		PTFE	60 {600}	10 {100}	65 {650}	10 {100}	-	-	-	-
150	6	EPDM	40 {400}	15 {150}	45 {450}	10 {100}	-	-	-	-
		PTFE	65 {650}	15 {150}	70 {700}	10 {100}	-	-	-	-
200	8	EPDM	40 {400}	20 {200}	45 {450}	15 {150}	-	-	-	-
		PTFE	70 {700}	20 {200}	70 {700}	15 {150}	-	-	-	-

TEST METHOD [Vertical piping]

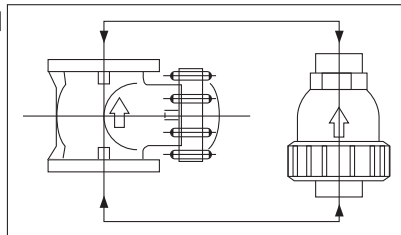

[Horizontal piping]

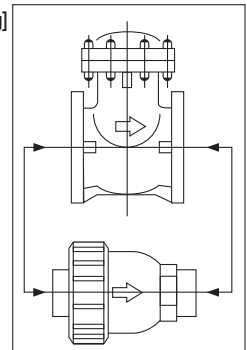

Measure the minimum pressure required for air to pass through or to be sealed.

## PERFORMANCE OF WAFER CHECK VALVE

Min. sealing pressure / operating pressure (water pressure) Unit: kpa {gf/m<sup>2</sup>} {PSI}

mm	inch	STANDARD MODEL				SPRING MODEL			
		VERTICAL PIPING		HORIZONTAL PIPING		VERTICAL PIPING		HORIZONTAL PIPING	
		MIN. SEALING PRESSURE	OPERATING PRESSURE	MIN. SEALING PRESSURE	OPERATING PRESSURE	MIN. SEALING PRESSURE	OPERATING PRESSURE	MIN. SEALING PRESSURE	OPERATING PRESSURE
80	3	21.0	0.7	21.0	0.07	21.0	1.4	21.0	0.07
		{210.0}{3.0}	{7.0}{0.1}	{210.0}{3.0}	{0.7}{0.01}	{210.0}{3.0}	{14.0}{0.2}	{210.0}{3.0}	{0.7}{0.01}
100-300	4-12	7.0	0.7	7.0	0.07	7.0	1.4	7.0	0.07
		{70.0}{1.0}	{7.0}{0.1}	{70.0}{1.0}	{0.7}{0.01}	{70.0}{1.0}	{14.0}{0.2}	{70.0}{1.0}	{0.7}{0.01}

TEST METHOD [Vertical piping]

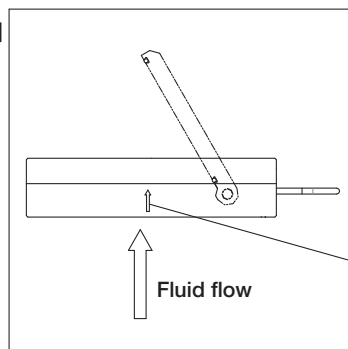

[Horizontal piping]

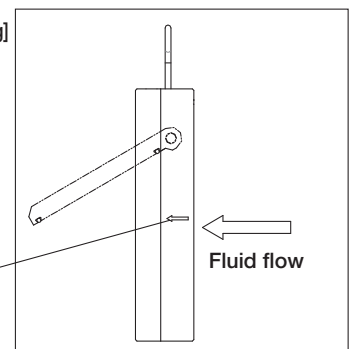

Arrow

# SWING CHECK VALVE

- PREVENTS FLUID BACKFLOW AND PROTECTS PUMP FACILITIES
- ARM-TYPE CHECK VALVE PREVENTS FLUID RESISTANCE INCREASE.
- ALL-PLASTIC MATERIAL PROVIDES HIGH RESISTANCE TO CORROSIVE FLUID INCLUDING ACID AND ALKALI.
- INTERNAL MAINTENANCE ONLY REQUIRES REMOVAL OF BONNET.

## BASIC SPECIFICATIONS

VALVE TYPE ————— SWING CHECK VALVE

SIZE ————— 15 mm—200 mm (1/2 inch—8 inch)

BODY MATERIAL ————— **HI-PVC** **PP** **PVDF**

SEAL MATERIAL / SEAT ————— **EPDM** **FKM** **PTFE**  
**Viflon-F** **Viflon-C**

CONNECTION / FLANGED — JIS5K, JIS10K, DIN, ANSI

	FLUID TEMPERATURE	MAXIMUM WORKING PRESSURE (NORMAL TEMPERATURE) MPa(kgf/cm <sup>2</sup> )		
		15mm—80mm	100mm—150mm	200mm
<b>HI-PVC</b>	0°C ~ 50°C	1.0 {10.2}	0.7 {7.1}	0.5 {5.1}
<b>PP</b>	-20°C ~ 80°C	1.0 {10.2}	0.7 {7.1}	0.5 {5.1}
<b>PVDF</b>	-20°C ~ 100°C	1.0 {10.2}	0.7 {7.1}	0.5 {5.1}

**NOTE** The maximum working pressure is the value including the water hammer pressure. Be careful that the maximum working pressure is not exceeded during use.  
 \* Concerning the allowable pressure for each temperature and material, see the technical documents at the end of this catalog.

MANUAL



### NOTES FOR PIPING

- They can be used for both horizontal and vertical pipes, but make sure during installation that the arrow direction of the valve body is aligned with the flow direction of the fluid.

### NOTES FOR USE

- If foreign matter such as dust is mixed in the fluid, the valve may not function properly.
- The plug (P/N ④) is not a drain plug for water removal. Do not remove the plug to discharge water since the valve may become unable to work properly.

**NOTE** For information on how to drain water, contact our sales office in your area.

## PARTS LIST **MANUAL**

### HI-PVC, PVDF

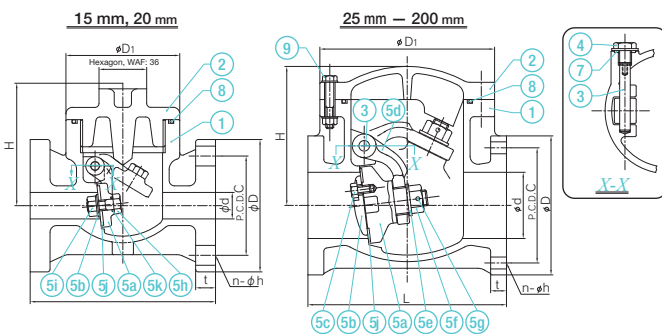

PART NO. / NAME	QTY	MATERIAL	PART NO. / NAME	QTY	MATERIAL
① BODY	1	HI-PVC, PVDF	⑤f NUT (A) <sup>(4)</sup>	1	HI-PVC, PVDF
② BONNET	1	HI-PVC, PVDF	⑤g PIN <sup>(3)</sup>	1	HI-PVC, PVDF
③ SHAFT	1	HI-PVC, PVDF	⑤h BOLT (B) <sup>(1)</sup>	1	HI-PVC, PVDF
④ PLUG	1	HI-PVC, PVDF	⑤i NUT (B) <sup>(1)</sup>	1	HI-PVC, PVDF
⑤a DISC	1	HI-PVC, PVDF	⑤j SEAT	1	GASKET — O-RING (B) SEAT — O-RING (A)
⑤b SEAT HOLDER	1	HI-PVC, PVDF	⑤k O-RING (A) <sup>(1)</sup>	1	EPDM — EPDM FKM — FKM PTFE — PFA <sup>(2)</sup>
⑤c BOLT (A) <sup>(4)</sup>	—	HI-PVC, PVDF	⑦ GASKET (B)	1	
⑤d ARM <sup>(4)</sup>	1	HI-PVC, PVDF	⑧ O-RING (B)	1	
⑤e WASHER <sup>(4)</sup>	1	HI-PVC, PVDF	⑨ BOLT/NUT <sup>(4)</sup>	—	SUS304

**NOTES** (1) Used for 15 mm and 20 mm. (2) FKM + PFA coating.  
 (3) Used for the material of PVDF and sizes of 65 to 200 mm.  
 (4) Used for 25 to 200 mm.

### PP

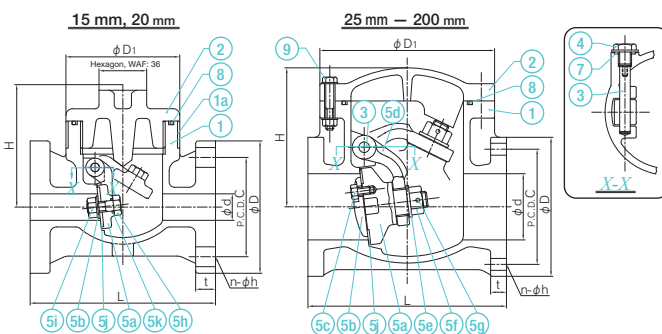

PART NO. / NAME	QTY	MATERIAL	PART NO. / NAME	QTY	MATERIAL
① BODY	1	PP	⑤g PIN <sup>(2)</sup>	1	PVDF
② BONNET	1	PP	⑤h BOLT (B) <sup>(1)</sup>	1	PP
③ SHAFT	1	PP	⑤i NUT (B) <sup>(1)</sup>	1	PP
④ PLUG	1	PP	⑤j SEAT	1	GASKET — O-RING (B) SEAT — O-RING (A)
⑤a DISC	1	PVDF	⑤k O-RING (A) <sup>(1)</sup>	1	EPDM — EPDM FKM — FKM
⑤b SEAT HOLDER	1	PP	⑦ GASKET (B)	1	
⑤c BOLT (A) <sup>(3)</sup>	—	PP	⑧ O-RING (B)	1	
⑤d ARM <sup>(3)</sup>	1	PP	⑨ BOLT/NUT <sup>(3)</sup>	—	SUS304
⑤e WASHER <sup>(3)</sup>	1	PP	①a BODY RING <sup>(1)</sup>	1	SUS304
⑤f NUT (A) <sup>(3)</sup>	1	PVDF			

**NOTES** (1) Used for 15 mm and 20 mm. (2) Used for 65 to 200 mm.  
 (3) Used for 25 to 200 mm.

**PRODUCT MODEL CODE LIST**

**MANUAL**

ACTUATION	TYPE	BONNET SEAL	BODY MATERIAL	SEAL MATERIAL	CONNECTION	STANDARD	SIZE
V	SC	OR*	*	*	F	*	***
⋮	⋮	⋮	⋮	⋮	⋮	⋮	⋮
V MANUAL VALVE	SC SWING	OR O-RING	I HI-PVC P PP F PVDF	E EPDM V FKM P PTFE/PFA 3 PTFE/Vitflon-F 4 PTFE/Vitflon-C	F FLANGED	1 10K 5 5K D DIN A ANSI	015 15mm 200 200mm

\* When the seal material is EPDM or FKM, the material of O-ring is the same as that of the seal.  
When the seal material is PTFE, the material of O-ring is PFA coating or Vitflon.

**NOTES** • 15 mm type is processed from 20 mm. 32 mm type is processed from 40 mm.

• Contact us regarding the combination of body material PP and seal material PTFE/PFA.

**MANUAL**

# SWING CHECK VALVE

TYPE—VSCOR

CONNECTION / FLANGED—JIS, DIN, ANSI

HI-PVC, PVDF

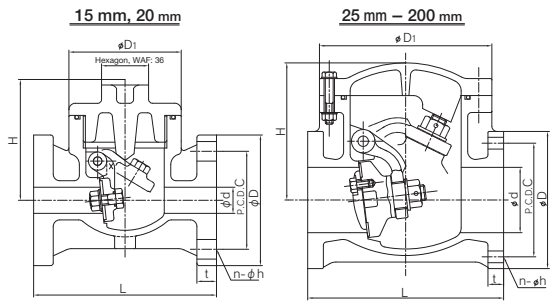

PP

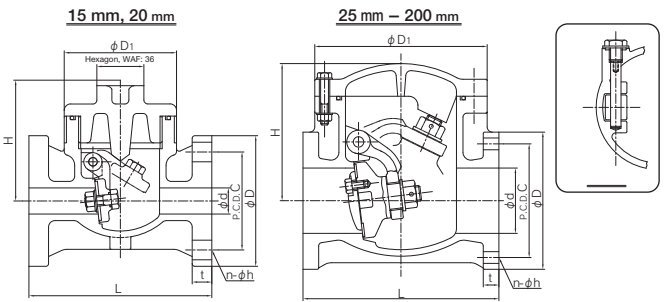

■ JIS, DIN (Unit: mm)

mm	d	D <sub>1</sub>	H	L	t			JIS5K				JIS10K				DIN PN10			
					HI-PVC	PVDF	PP	D	C	n	h	D	C	n	h	D	C	n	h
15	20	86	87	140	15	15	15	80	60	4	12	95	70	4	15	95	65	4	14
20	20	86	87	140	15	15	15	85	65	4	12	100	75	4	15	105	75	4	14
25	25	130	117	160	16	16	16	95	75	4	12	125	90	4	19	115	85	4	14
32	40	145	135	180	18	18	17	-	-	-	-	135	100	4	19	140	100	4	18
40	40	145	135	180	18	18	17	120	95	4	15	140	105	4	19	150	110	4	18
50	50	180	161	200	20	20	20	130	105	4	15	155	120	4	19	165	125	4	18
65	65	200	165	240	22	23	22	155	130	4	15	175	140	4	19	185	145	4	18
80	80	205	168	260	22	23	22	180	145	4	19	185	150	8	19	200	160	8	18
100	100	265	210	300	24	26	24	200	165	8	19	210	175	8	19	220	180	8	18
125	125	330	245	350	24	26	25	235	200	8	19	250	210	8	23	250	210	8	18
150	150	370	280	400	25	27	26	265	230	8	19	280	240	8	23	285	240	8	22
200	200	425	333	500	30	33	31	320	280	8	23	330	290	12	23	340	295	8	22

■ ANSI (Unit: inch)

inch	mm	d	D <sub>1</sub>	H	L	t			ANSI Class150			
						HI-PVC	PVDF	PP	D	C	n	h
1/2	15	0.79	3.39	3.43	5.51	0.59	0.59	0.59	3.50	2.38	4	0.62
3/4	20	0.79	3.39	3.43	5.51	0.59	0.59	0.59	3.88	2.75	4	0.62
1	25	0.98	5.12	4.61	6.30	0.63	0.63	0.63	4.25	3.12	4	0.62
1 1/4	32	-	-	-	-	-	-	-	-	-	-	-
1 1/2	40	1.57	5.71	5.31	7.09	0.71	0.71	0.67	5.00	3.88	4	0.62
2	50	1.97	7.09	6.34	7.87	0.79	0.79	0.79	6.00	4.75	4	0.75
2 1/2	65	2.56	7.87	6.50	9.45	0.87	0.91	0.87	7.00	5.50	4	0.75
3	80	3.15	8.07	6.61	10.24	0.87	0.91	0.87	7.50	6.00	4	0.75
4	100	3.94	10.43	8.27	11.81	0.94	1.02	0.94	9.00	7.50	8	0.75
5	125	4.92	12.99	9.65	13.78	0.94	1.02	0.98	10.00	8.50	8	0.88
6	150	5.91	14.57	11.02	15.75	0.98	1.06	1.02	11.00	9.50	8	0.88
8	200	7.87	16.73	13.11	19.69	1.18	1.30	1.22	13.50	11.75	8	0.88

# WAFER CHECK VALVE

- STRENGTH CONCERNS OF PLASTIC WAFER CHECK ARE RESOLVED USING STRESS ANALYSIS.
- CORROSION RESISTANCE IS IMPROVED BY ALL-PLASTIC WETTED PART AND COATED SPRING.
- WEIGHT IS 1/3 TO 1/5 OF THAT OF METAL TYPE.
- STOPPER-INTEGRATED STRUCTURE ELIMINATES THE USE OF GASKET DURING PIPING, ALLOWING COST REDUCTION.

## BASIC SPECIFICATIONS

VALVE TYPE \_\_\_\_\_ WAFER CHECK VALVE

SIZE \_\_\_\_\_ 80 mm—300 mm (3 inch—12 inch)

BODY MATERIAL \_\_\_\_\_ U-PVC

SEAL MATERIAL / O-RING \_\_\_\_\_ EPDM FKM

CONNECTION / WAFER \_\_\_\_\_ JIS10K, DIN, ANSI

	FLUID TEMPERATURE	MAXIMUM WORKING PRESSURE (NORMAL TEMPERATURE) MPa(kgf/cm <sup>2</sup> )	
		80mm—200mm	250mm, 300mm
U-PVC	0°C ~ 50°C	1.0 {10.2}	0.6 {6.1}

**NOTES** The maximum working pressure is the value including the water hammer pressure. Be careful that the maximum working pressure is not exceeded during use.

\* Concerning the allowable pressure for each temperature and material, see the technical documents at the end of this catalog.

MANUAL



### NOTES FOR USE

- The maximum working pressure is the value including the water hammer pressure. Be careful that the maximum working pressure is not exceeded during use.
- The wafer check valve is most suited for water and sea water lines. When it is used for a chemical line, contact us to check the chemical resistance.
- They can be used for both horizontal and vertical pipes, but make sure during installation that the arrow direction of the valve body is aligned with the flow direction of the fluid.

## PARTS LIST

MANUAL

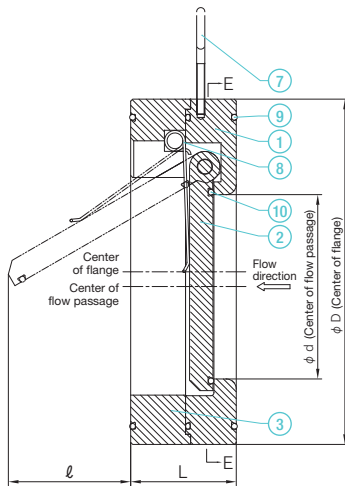

80 mm (3"), 100 mm (4"), 200 mm (8")

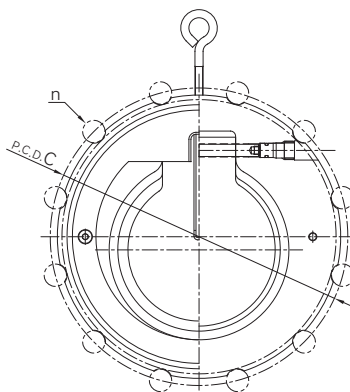

125 mm (5"), 150 mm (6"), 250 mm (10"), 300 mm (12")

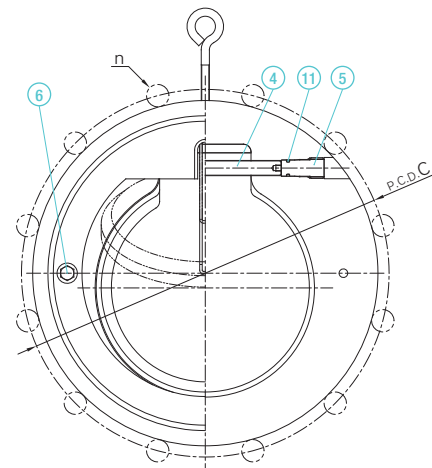

PART NO. / NAME	QTY	MATERIAL	PART NO. / NAME	QTY	MATERIAL	PART NO. / NAME	QTY	MATERIAL
① BODY	1	U-PVC	⑤ PLUG	1	U-PVC	⑨ O-RING (A)	3	EPDM, FKM
② DISC	1	U-PVC	⑥ BOLT	2	U-PVC	⑩ O-RING (B)	1	EPDM, FKM
③ STOPPER	1	U-PVC	⑦ EYE BOLT	1	SS400 (Unichrome plating)	⑪ O-RING (C)	1	EPDM, FKM
④ SHAFT	1	U-PVC	⑧ SPRING <sup>(1)</sup>	1	SWP-B (ETFE COATING)			

**NOTE** (1) Not used for standard type.

PRODUCT MODEL CODE LIST

MANUAL

ACTUATION	TYPE	OPERATING SYSTEM	BODY MATERIAL	SEAL MATERIAL	CONNECTION	STANDARD	SIZE
V	WC	ZZ	U	*	W	*	***
⋮	⋮	⋮	⋮	⋮	⋮	⋮	⋮
V MANUAL VALVE	WC WAFER CHECK	ZZ NONE	U U-PVC	E EPDM V FKM	W WAFER	D DIN A ANSI 1 10K	080 80mm ? 300 300mm

MANUAL

## WAFER CHECK VALVE

TYPE — WWCZ

CONNECTION / WAFER — JIS, ANSI, DIN

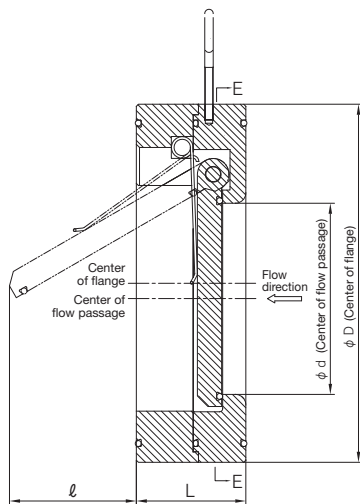

80 mm (3"), 100 mm (4"), 200 mm (8")

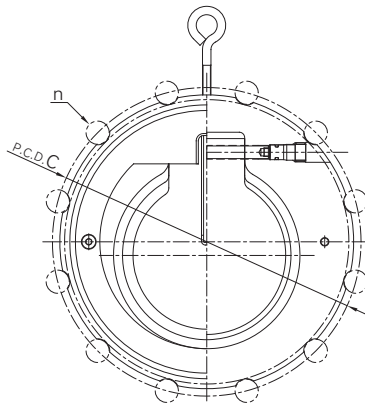

125 mm (5"), 150 mm (6"), 250 mm (10"), 300 mm (12")

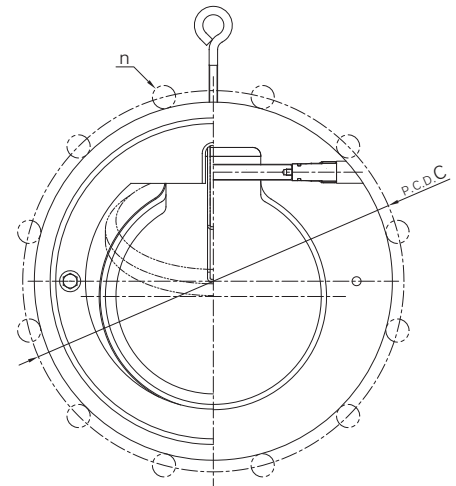

■ JIS, DIN (Unit: mm)

mm	d	D	L	ℓ	JIS10K		DIN PN10	
					C	n	C	n
80	47	144	63	22.6	150	8	160	8
100	52	175	70	34.9	175	8	180	8
125	77	190	76	50.9	210	8	210	8
150	92	220	82	64.8	240	8	240	8
200	132	279	101	93.6	290	12	295	8
250	177	333	114	129	355	12	350	12
300	217	378	115	165.6	400	16	400	12

■ ANSI (Unit: inch)

inch	mm	d	D	L	ℓ	ANSI Class150	
						C	n
3	80	1.85	5.67	2.48	0.89	6.00	4
4	100	2.05	6.89	2.76	1.37	7.50	8
5	125	3.03	7.48	2.99	2.00	8.50	8
6	150	3.62	8.66	3.23	2.55	9.51	8
8	200	5.20	10.98	3.98	3.69	11.75	8
10	250	6.97	13.11	4.49	5.08	14.25	12
12	300	8.54	14.88	4.53	6.52	17.01	12

# BALL CHECK VALVE

- PLASTIC VALVE WITH HIGH RESISTANCE TO BOTH INTERNAL AND EXTERNAL CORROSION CAUSED BY SEA WATER, VARIOUS ACIDS AND ALKALIS AND OTHER CHEMICALS.
- FLOW PASSAGE STRUCTURE WITH LOW FLUID RESISTANCE
- SMALL PARTS QUANTITY AND A SINGLE CONNECTION REDUCE EXTERNAL STRESS EFFECTS, ALLOWING HIGH FINISHING ACCURACY.
- LIGHTWEIGHT AND SMALL SIZE ALLOW INSTALLATION IN NARROW SPACES AND FACILITATE DISASSEMBLED CLEANING.

MANUAL

## BASIC SPECIFICATIONS

VALVE TYPE ————— BALL CHECK VALVE

SIZE ————— 15 mm—100 mm (1/2 inch—4 inch)

BODY MATERIAL ————— **U-PVC** **C-PVC** **PP** **PVDF**

SEAL MATERIAL / SEAT ————— **EPDM** **FKM** etc.

CONNECTION / FLANGED — JIS5K, JIS10K, DIN, ANSI

SOCKET — JIS, DIN, ANSI

THREADED— Rc, Rp, NPT

	FLUID TEMPERATURE	MAXIMUM WORKING PRESSURE (NORMAL TEMPERATURE (15°C)) (MPa)(kgf/cm <sup>2</sup> )		CONNECTION METHOD		
		15 mm—50 mm	80mm—100mm	FLANGED	SOCKET	THREADED
U-PVC	0°C ~ 50°C	1.0 {10.2}	0.7 {7.1}	○	○	○
C-PVC	0°C ~ 90°C	1.0 {10.2}	0.7 {7.1}	○	○	○
PP	-20°C ~ 80°C	1.0 {10.2}	0.5 {5.1}	—	○	○
PVDF	-20°C ~ 100°C	1.0 {10.2}	0.7 {7.1}	—	○	○

**NOTES** The maximum working pressure is the value including the water hammer pressure. Be careful that the maximum working pressure is not exceeded during use.

\* Concerning the allowable pressure for each temperature and material, see the technical documents at the end of this catalog. \* For flanged type 15 - 50 mm with the body material of PP or PVDF, true union ball check valves can be used. For details, contact our sales office.

\* The minimum operating pressure is shown on the next page (ball foot valve).



### NOTES FOR USE

- Make sure during piping that the arrow direction of the valve body is aligned with the flow direction of the fluid.
- Do not use the valve in a line where the fluid flow is very turbulent. Oscillation of the ball may occur in the valve, causing breakage.
- Near pumps with unstable flow, use AV swing check valves.

## PARTS LIST

MANUAL

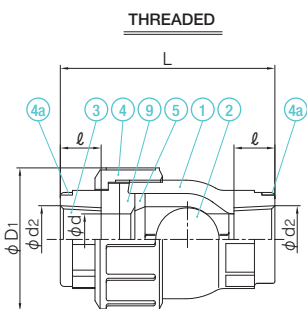
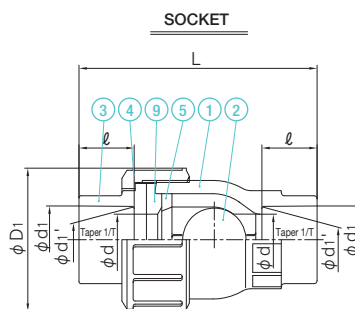
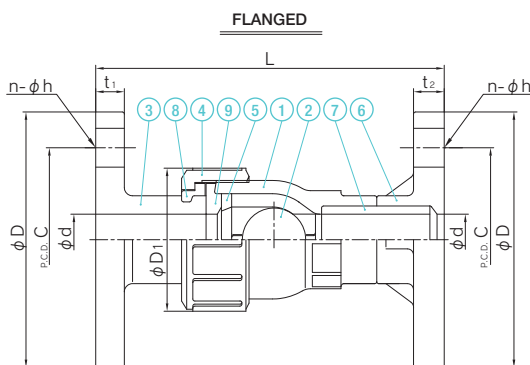

PART NO. / NAME	QTY	MATERIAL
① BODY	1	
② BALL	1	FLANGED
③ END CONNECTOR	1	U-PVC, C-PVC
④ UNION NUT	1	SOCKET
⑤ STOP RING (A)	1	U-PVC, C-PVC, PP, PVDF
⑥ TS FLANGE <sup>(2)</sup>	1	THREADED
⑦ PIPE <sup>(2)</sup>	1	U-PVC, C-PVC, PP, PVDF

PART NO. / NAME	QTY	MATERIAL
⑧ STOP RING (B) <sup>(2)</sup>	1	PVDF
⑨ SEAT	1	EPDM, FKM, etc.
④a RING <sup>(1)</sup>	2	SUS304

**NOTES** (1) Used for 15 to 25 mm for C-PVC threaded type. (2) Used for flanged type.

**PRODUCT MODEL CODE LIST**  
[MANUAL](#)

ACTUATION	TYPE	OPERATING SYSTEM	BODY MATERIAL	SEAL MATERIAL	CONNECTION	STANDARD	SIZE
V	BC	ZZ	*	*	*	*	***
V MANUAL VALVE	BC BALL CHECK	ZZ NONE	U U-PVC C C-PVC P PP F PVDF	E EPDM V FKM	S SOCKET N THREADED F FLANGED P SPIGOT	J JIS 1 10K 5 5K D DIN A ANSI	015 15mm 100 100mm

**NOTES**

- PP and PVDF socket types are weld type.
- PVDF socket type compatible with the JIS standard is not available.

- For 32 mm and 65 mm flanged types, individual service may be available. Contact us for more details.
- PP and PVDF flanged types are not produced.

[MANUAL](#)

## BALL CHECK VALVE

TYPE—VBCZZ

CONNECTION / FLANGED, SOCKET, THREADED—JIS, DIN, ANSI SPIGOT—DIN

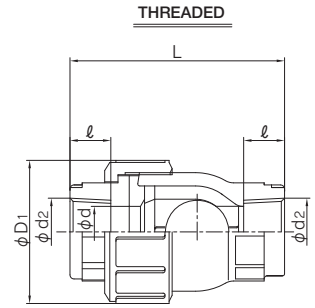
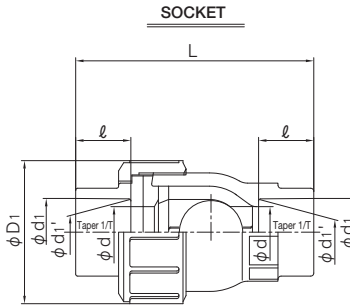
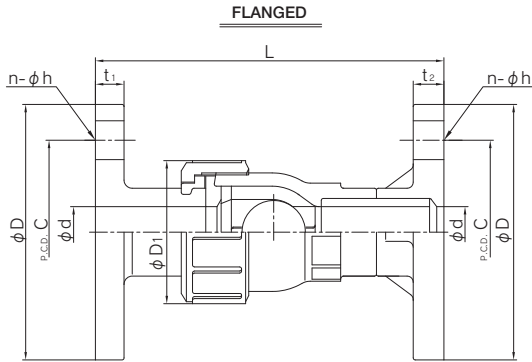

JIS (Unit: mm)		FLANGED														SOCKET								THREADED				
mm	d	D <sub>1</sub>	JIS5K						JIS10K						U-PVC C-PVC				PP				JIS B 0203		L			
			D	C	n	h	t <sub>2</sub>	t <sub>1</sub>	D	C	n	h	t <sub>2</sub>	t <sub>1</sub>	d <sub>1</sub>	ℓ	1/T	L	d <sub>1</sub>	d <sub>2</sub>	ℓ	L	d <sub>1</sub>	ℓ	U-PVC C-PVC	PVDF PP		
15	15	48	80	60	4	12	9	9	95	70	4	15	14	14	131	12	22.11	20	1/34	89	21.2	20.2	22	93	Rc 1/2	15	80	78
20	20	60	85	65	4	12	10	10	100	75	4	15	15	14	156	14	26.13	24	1/34	106	26.2	25.2	23	104	Rc 1/4	17	95	92
25	25	70	95	75	4	12	10	10	125	90	4	19	15	16	169	14	32.16	27	1/34	117	33.0	32.0	25	113	Rc 1	20	105	102
40	40	96	120	95	4	15	12	12	140	105	4	19	16	16	214	16	48.21	37	1/37	162	47.0	46.0	28	144	Rc 1 1/2	25	141	137
50	51	106	130	105	4	15	14	14	155	120	4	19	20	20	244	16	60.25	42	1/37	189	59.0	58.0	28	162	Rc 2	28	164	160
80	78	152	180	145	4	19	14	-	185	150	8	19	22	22	310	18	89.60	64	1/49	277	88.0	86.0	35	219	Rc 3	35	222	216
100	100	210	200	165	8	19	16	-	210	175	8	19	22	22	397	18	114.70	84	1/56	376	113.0	111.0	45	298	Rc 4	45	308	301

DIN (Unit: mm)		SOCKET								THREADED				SPIGOT					
mm	d	D <sub>1</sub>	U-PVC C-PVC				PP PVDF				DIN 2999				DIN 3442				
			DIN 8063		L		DIN 16962		L		d <sub>1</sub>	ℓ	L		d <sub>3</sub>	t <sub>1</sub>		ℓ	L
			d <sub>1</sub>	ℓ	L	d <sub>1</sub>	d <sub>2</sub>	ℓ	L	U-PVC C-PVC			PVDF PP	PP		PVDF			
15	15	48	20	16	81	19.50	19.30	14	78	Rp 1/2	15	80	78	20	2.5	1.9	19.0	100	
20	20	60	25	19	96	24.50	24.30	16	90	Rp 1/4	17	95	92	25	2.7	1.9	19.0	110	
25	25	70	32	22	107	31.50	31.30	18	99	Rp 1	20	105	102	32	3.0	2.4	19.0	116	
40	40	96	50	31	150	49.45	49.20	23	135	Rp 1 1/2	25	141	137	50	4.6	2.9	19.0	142	
50	51	106	63	38	181	62.50	62.10	27	160	Rp 2	28	164	160	63	5.8	3.0	19.0	157	
80	78	152	90	51	248	89.20	88.85	35	217	Rp 3	35	222	216	90	8.2	4.3	38.0	256	
100	100	210	110	61	330	109.05	108.65	41	291	Rp 4	45	308	301	110	10.0	5.3	44.5	333	

ANSI (Unit: inch)		FLANGED										SOCKET								THREADED					
inch	mm	d	D <sub>1</sub>	ANSI CLASS 150						L				U-PVC C-PVC ASTM SCH40				PVDF PP				ANSI/ASME B 1.20.1			
				D	C	n	h	U-PVC	t <sub>1</sub>	t <sub>2</sub>	d <sub>1</sub>	d <sub>2</sub>	ℓ	L	d <sub>1</sub>	d <sub>2</sub>	ℓ	L	d <sub>1</sub>	ℓ	U-PVC C-PVC	PVDF PP	d <sub>1</sub>	ℓ	L
				D	C	n	h	U-PVC	t <sub>1</sub>	t <sub>2</sub>															
1/2	15	0.59	1.89	3.50	2.38	4	0.63	5.16	0.47	0.55	0.848	0.836	0.688	3.35	0.825	-	0.874	3.82	1/2-14NPT	0.59	3.15	3.07			
3/4	20	0.79	2.36	3.86	2.75	4	0.63	6.14	0.55	0.59	1.058	1.046	0.719	3.74	1.030	-	1.000	4.41	3/4-14NPT	0.67	3.74	3.62			
1	25	0.98	2.76	4.25	3.12	4	0.63	6.65	0.55	0.59	1.325	1.310	0.875	4.33	1.300	-	1.126	4.88	1-11 1/2 NPT	0.79	4.13	4.02			
1 1/2	40	1.57	3.78	5.00	3.88	4	0.63	8.43	0.63	0.63	1.912	1.894	1.094	5.71	1.890	-	1.374	5.79	1 1/2-11 1/2 NPT	0.98	5.55	5.39			
2	50	2.01	4.17	5.98	4.75	4	0.75	9.61	0.63	0.79	2.387	2.369	1.156	6.50	2.360	-	1.500	6.89	2-11 1/2 NPT	1.10	6.46	6.30			
3	80	3.07	5.98	7.52	6.00	4	0.75	12.20	0.71	0.87	3.516	3.492	1.875	9.57	3.480	-	1.874	9.57	3-8NPT	1.38	8.74	8.50			
4	100	3.94	8.27	9.02	7.50	8	0.75	15.63	0.71	0.87	4.518	4.491	2.000	12.20	4.480	-	2.252	12.68	4-8NPT	1.77	12.13	11.85			



# TRUE UNION BALL CHECK VALVE

- THE VALVE PARTS CAN BE REMOVED WITHOUT DISCONNECTING THE PIPES, BY LOOSENING THE UNIONS ON BOTH SIDES

## BASIC SPECIFICATIONS

VALVE TYPE ————— TRUE UNION BALL CHECK VALVE

SIZE ————— 15 mm—50 mm (1/2 inch—2 inch)

BODY MATERIAL ————— **U-PVC** **C-PVC** **PP** **PVDF**

SEAL MATERIAL / SEAT — **EPDM** **FKM** etc.

CONNECTION / FLANGED — DIN, ANSI

SOCKET — DIN, ANSI

THREADED—Rp, NPT

SPIGOT — DIN

	FLUID TEMPERATURE	MAXIMUM WORKING PRESSURE (NORMAL TEMPERATURE) MPa(kgf/cm <sup>2</sup> )	CONNECTION METHOD		
			FLANGED	SOCKET	THREADED
<b>PVDF</b>	-20°C ~ 100°C	1.0 {10.2}	○	○	○
<b>PP</b>	-20°C ~ 80°C	1.0 {10.2}	○	○	○

**NOTES** The maximum working pressure is the value including the water hammer pressure. Be careful that the maximum working pressure is not exceeded during use.  
\* Concerning the allowable pressure for each temperature and material, see the technical documents at the end of this catalog.

MANUAL

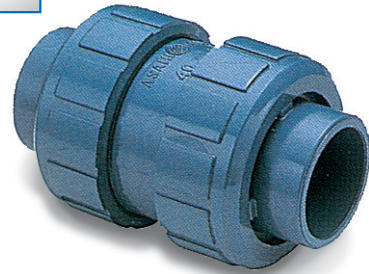

## PARTS LIST MANUAL

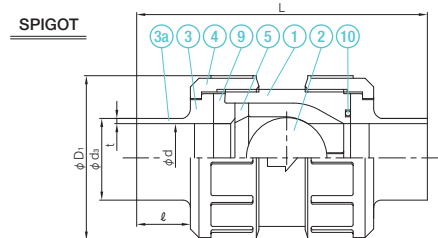
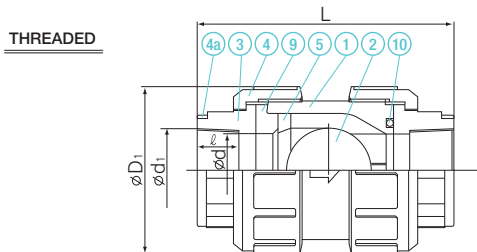
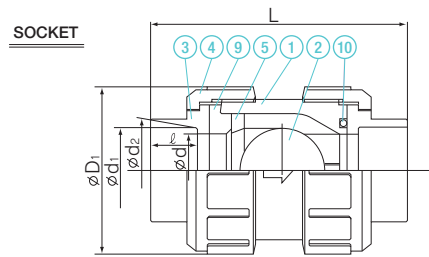
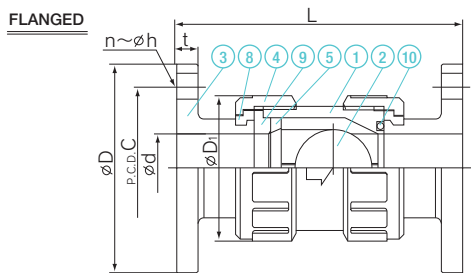

PART NO. / NAME	QTY	MATERIAL
① BODY	1	
② BALL	1	
③ END CONNECTOR	2	U-PVC, C-PVC, PP, PVDF
④ UNION NUT	2	
⑤ STOP RING (A)	1	

PART NO. / NAME	QTY	MATERIAL
⑧ STOP RING (B) <sup>(2)</sup>	2	PVDF
⑨ SEAT	1	EPDM, FKM, etc.
⑩ O-RING	1	EPDM, FKM, etc.
④a RING <sup>(1)</sup>	2	SUS304

**NOTES** (1) Used for 15 to 25 mm for C-PVC threaded type. (2) Used for flanged type.

**PRODUCT MODEL CODE LIST**  
[MANUAL](#)

ACTUATION	TYPE	OPERATING SYSTEM	BODY MATERIAL	SEAL MATERIAL	CONNECTION	STANDARD	SIZE
V	TC	ZZ	*	*	*	*	***
⋮	⋮	⋮	⋮	⋮	⋮	⋮	⋮
V MANUAL VALVE	TC TRUE UNION BALL CHECK	ZZ NONE	U U-PVC C C-PVC P PP F PVDF	E EPDM V FKM	S SOCKET N THREADED F FLANGED P SPIGOT	D DIN A ANSI	015 15mm ? 050 50mm

[MANUAL](#)

## TRUE UNION BALL CHECK VALVE

TYPE—VTCZ

CONNECTION / FLANGED, SOCKET, THREADED, SPIGOT—DIN

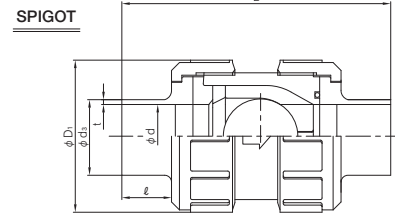
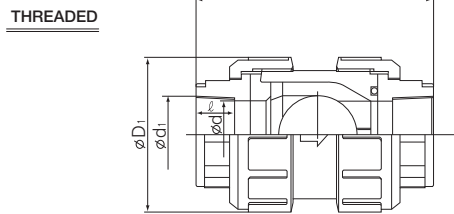
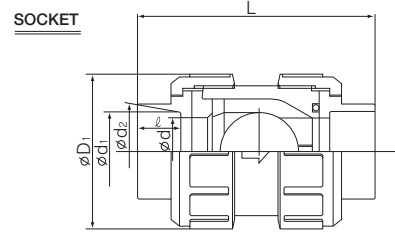
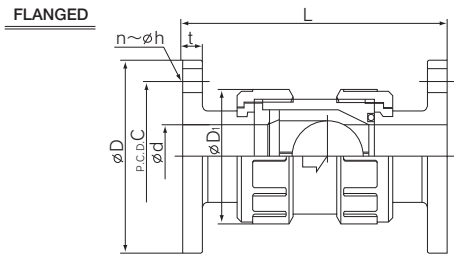

■ DIN (Unit: mm)

mm	d	D <sub>1</sub>	FLANGED							SOCKET						
			DIN PN10				L			U-PVC C-PVC			PVDF PP			
			D	C	n	h	U-PVC C-PVC	PP	t	DIN 8063		L	DIN 16962			
d <sub>1</sub>	ℓ	L	d <sub>1</sub>	d <sub>2</sub>	ℓ	L										
15	15	48	95	65	4	14	130	128	12	20	16	84	19.50	19.30	14	79
20	20	60	105	75	4	14	155	154	14	25	19	100	24.50	24.30	16	93
25	25	70	115	85	4	14	165	163	14	32	22	113	31.50	31.30	18	103
40	40	96	150	110	4	18	192	190	16	50	31	158	49.45	49.20	23	141
50	51	106	165	125	4	18	214	211	16	63	38	190	62.50	62.10	27	167

mm	d <sub>s</sub>	SPIGOT									THREADED			
		U-PVC			PP			PVDF			DIN 2999		L	
		t	ℓ	L	t	ℓ	L	t	ℓ	L	d <sub>1</sub>	ℓ	U-PVC C-PVC	PVDF PP
15	20	2.5	16	113	2.5	19	102	1.9	19	102	Rp 1/2	15	86	83
20	25	2.5	18.5	127	2.7	19	110	1.9	19	110	Rp 3/4	17	103	98
25	32	3.5	22	132	3	19	118	2.4	19	118	Rp 1	20	113	109
40	50	5	31	174	4.6	19	145	2.9	19	145	Rp 1 1/2	25	151	147
50	63	6.5	37.5	204	5.8	19	164	3	19	164	Rp 2	28	177	171

ANSI (Unit: inch)

inch	mm	d	D <sub>1</sub>	FLANGED							SOCKET						THREADED					
				ANSI Class 150				L			U-PVC C-PVC			PVDF PP			ANSI/ASME B 1.20.1		L			
				D	C	n	h	U-PVC C-PVC	PP	t <sub>1</sub>	ASTM SCH40		L	d <sub>1</sub>	d <sub>1</sub> '	ℓ	L	d <sub>1</sub>	ℓ	U-PVC C-PVC	PP PVDF	
d <sub>1</sub>	d <sub>2</sub>	ℓ	L	d <sub>1</sub>	d <sub>1</sub> '	ℓ	L															
1/2	15	0.59	1.89	3.50	2.38	4	0.62	5.12	5.04	0.47	0.848	0.836	0.688	3.43	0.831	-	0.630	3.23	1/2-14NPT	0.59	3.39	3.27
3/4	20	0.79	2.36	3.88	2.75	4	0.62	6.10	6.06	0.55	1.058	1.046	0.719	3.86	1.041	-	1.000	4.37	3/4-14NPT	0.67	4.06	3.86
1	25	0.98	2.76	4.25	3.12	4	0.62	6.50	6.42	0.55	1.325	1.310	0.875	4.37	1.305	-	0.827	4.29	1-11 1/2NPT	0.79	4.45	4.29
1 1/2	40	1.57	3.78	5.00	3.88	4	0.62	7.56	7.48	0.63	1.912	1.894	1.094	5.94	1.889	-	1.260	6.22	1 1/2-11 1/2NPT	0.98	5.94	5.79
2	50	2.01	4.17	6.00	4.75	4	0.75	8.43	8.31	0.63	2.387	2.369	1.156	6.77	2.364	-	1.260	6.93	2-11 1/2NPT	1.10	6.97	6.73

# BALL FOOT VALVE

- INTEGRAL MOLDING WITH SCREEN INCREASES STRENGTH AT CONNECTION AREA.
- FLOW PASSAGE STRUCTURE WITH LOW FLUID RESISTANCE
- SMALL PARTS QUANTITY AND A SINGLE CONNECTION REDUCE EXTERNAL STRESS EFFECTS, ALLOWING HIGH FINISHING ACCURACY.
- LIGHTWEIGHT AND SMALL SIZE ALLOW INSTALLATION IN NARROW SPACES AND FACILITATE DISASSEMBLED CLEANING.

## BASIC SPECIFICATIONS

VALVE TYPE ————— BALL FOOT VALVE

SIZE ————— 15 mm—100 mm (1/2 inch—4 inch)

BODY MATERIAL ————— **U-PVC** **C-PVC** **PP** **PVDF**

SEAL MATERIAL / SEAT — **EPDM** **FKM** etc.

CONNECTION / FLANGED — JIS5K, JIS10K, DIN, ANSI

SOCKET — JIS, DIN, ANSI

THREADED— Rc, Rp, NPT

	FLUID TEMPERATURE	MAXIMUM WORKING PRESSURE (NORMAL TEMPERATURE) MPa(kgf/cm <sup>2</sup> )		CONNECTION METHOD		
		15 mm—50 mm	80mm—100mm	FLANGED	SOCKET	THREADED
U-PVC	0°C ~ 50°C	1.0 {10.2}	0.7 {7.1}	○	○	○
C-PVC	0°C ~ 90°C	1.0 {10.2}	0.7 {7.1}	○	○	○
PP	-20°C ~ 80°C	1.0 {10.2}	0.5 {5.1}	—	○	○
PVDF	-20°C ~100°C	1.0 {10.2}	0.7 {7.1}	—	○	○

**NOTES** The maximum working pressure is the value including the water hammer pressure. Be careful that the maximum working pressure is not exceeded during use.

\* Concerning the allowable pressure for each temperature and material, see the technical documents at the end of this catalog.

MANUAL



## PARTS LIST MANUAL

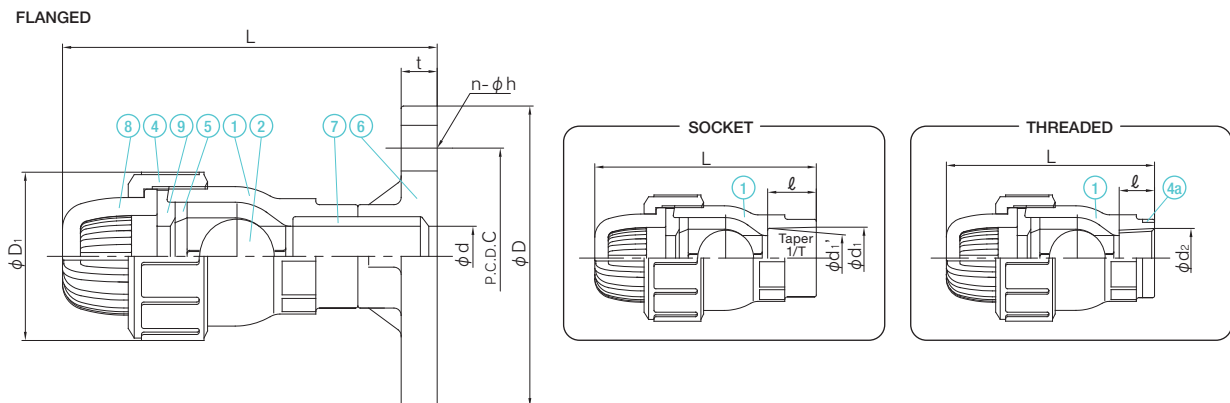

PART NO. / NAME	QTY	MATERIAL
① BODY	1	
② BALL	1	FLANGED
④ UNION NUT	1	U-PVC, C-PVC
⑤ STOP RING (A)	1	SOCKET
⑥ TS FLANGE	1	U-PVC, C-PVC, PP, PVDF
⑦ PIPE	1	THREADED
⑧ SCREEN	1	U-PVC, C-PVC, PP, PVDF

PART NO. / NAME	QTY	MATERIAL
⑨ SEAT	1	EPDM, FKM, etc.
④a RING <sup>(1)</sup>	1	SUS304

**NOTES** (1) Used for 15 to 25 mm for body material of C-PVC and connection of threaded type. (2) Used for flanged type. (3) PP flanged type is not produced.

**PRODUCT MODEL CODE LIST**  
**MANUAL**

ACTUATION	TYPE	OPERATING SYSTEM	BODY MATERIAL	SEAL MATERIAL	CONNECTION	STANDARD	SIZE
V	FT	ZZ	*	*	*	*	***
⋮	⋮	⋮	⋮	⋮	⋮	⋮	⋮
V MANUAL VALVE	FT BALL FOOT	ZZ NONE	U U-PVC C C-PVC P PP F PVDF	E EPDM V FKM	S SOCKET N THREADED F FLANGED	J JIS 1 10K 5 5K D DIN A ANSI	015 15mm ? 100 100mm

- NOTES**
- PP and PVDF socket types are weld type.
  - PVDF sockets are of DIN type only.
  - For 32 mm and 65 mm flanged types, individual service may be available. Contact us for more details.
  - PP and PVDF flanged types are not produced.

**MANUAL**

## BALL FOOT VALVE

TYPE—VFTZZ

CONNECTION / FLANGED, SOCKET—JIS, DIN, ANSI THREADED—Rc, Rp, NPT

FLANGED

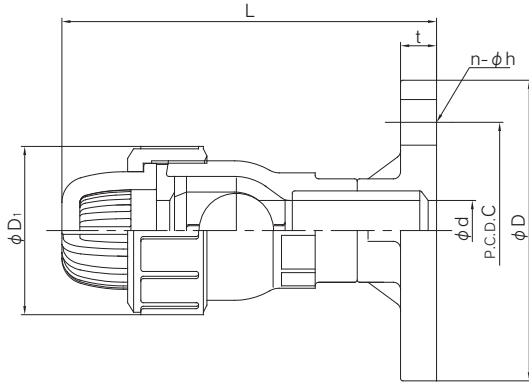

SOCKET

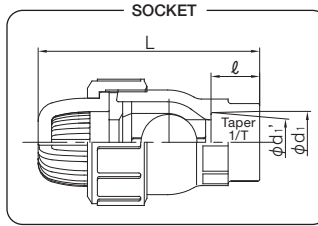

THREADED

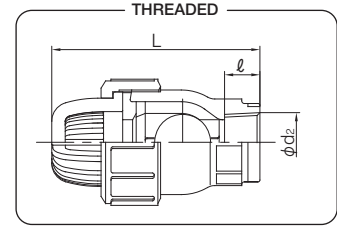

■ JIS (Unit: mm)

mm	D <sub>1</sub>	d	FLANGED											SOCKET				THREADED							
			JIS5K				JIS 10K				L			U-PVC C-PVC				PP							
			D	C	n	h	D	C	n	h	U-PVC	C-PVC	t	d <sub>1</sub>	ℓ	1/T	L	d <sub>1</sub>	d <sub>2</sub>	ℓ	L	d <sub>2</sub>	ℓ	U-PVC C-PVC	PVDF PP
15	48	18	80	60	4	12	95	70	4	15	130	130	14	22.11	20	1/34	95	21.2	20.2	22	97	Rc 1/2	15	90	88
20	60	22	85	65	4	12	100	75	4	15	150	150	15	26.13	24	1/34	110	26.2	25.2	23	108	Rc 1/4	17	103	101
25	70	25	95	75	4	12	125	90	4	19	167	171	15	32.16	27	1/34	121	33.0	32.0	25	118	Rc 1	20	114	111
40	96	41	120	95	4	15	140	105	4	19	246	250	16	48.21	37	1/37	184	47.0	46.0	28	174	Rc 1 1/2	25	172	169
50	106	52	130	105	4	15	155	120	4	19	274	277	20	60.25	42	1/37	203	59.0	58.0	28	188	Rc 2	28	189	185
80	152	78	180	145	4	19	185	150	8	19	396	409	22	89.60	64	1/49	323	88.0	86.0	35	293	Rc 3	35	294	289
100	210	100	200	165	8	19	210	175	8	19	506	518	22	114.70	84	1/56	413	113.0	111.0	45	372	Rc 4	45	374	367

■ DIN (Unit: mm)

mm	SOCKET								THREADED			
	U-PVC C-PVC				PP PVDF							
	d <sub>1</sub>	ℓ	L	d <sub>1</sub>	d <sub>1</sub> '	ℓ	L	d <sub>2</sub>	ℓ	L		
15	20	16	91	19.50	19.30	14.5	89	Rp 1/2	15	90	88	
20	25	19	105	24.50	24.30	16	101	Rp 3/4	17	103	101	
25	32	22	116	31.50	31.30	18	111	Rp 1	20	114	111	
40	50	31	178	49.45	49.20	23.5	169	Rp 1 1/2	25	172	169	
50	63	38	199	62.50	62.10	27.5	187	Rp 2	28	189	184	
80	90	51	310	89.20	88.85	35.5	293	Rp 3	35	294	288	
100	110	61	390	109.05	108.65	41.5	368	Rp 4	45	374	366	

■ ANSI (Unit: inch)

inch	mm	d	D <sub>1</sub>	FLANGED							SOCKET				THREADED			
				D	C	n	h	L	t	d <sub>1</sub>	d <sub>1</sub> '	ℓ	L	d <sub>2</sub>	ℓ	L		
				U-PVC	U-PVC	U-PVC	U-PVC	U-PVC	U-PVC	U-PVC	U-PVC	U-PVC	U-PVC	U-PVC	U-PVC	PVDF	PP	
1/2	15	0.71	1.89	3.50	2.38	4	0.62	5.55	0.47	0.848	0.836	0.69	3.74	1/2-14NPT	0.59	3.54	3.46	
3/4	20	0.87	2.36	3.86	2.76	4	0.62	6.42	0.51	1.058	1.046	0.72	4.17	3/4-14NPT	0.67	4.06	3.98	
1	25	0.98	2.76	4.25	3.13	4	0.62	6.73	0.59	1.325	1.310	0.87	4.76	1-11 1/2 NPT	0.79	4.49	4.37	
1 1/2	40	1.61	3.78	5.00	3.88	4	0.62	9.80	0.63	1.912	1.894	1.09	6.97	1 1/2-11 1/2 NPT	0.98	6.77	6.65	
2	50	2.05	4.17	5.98	4.74	4	0.75	10.91	0.79	2.387	2.369	1.16	7.60	2-11 1/2 NPT	1.10	7.44	7.24	
3	80	3.07	5.98	7.52	6.00	4	0.75	16.10	0.87	3.516	3.492	1.87	12.09	3-8NPT	1.38	11.57	11.34	
4	100	3.94	8.27	9.02	7.50	8	0.75	20.41	0.87	4.518	4.491	2.00	14.96	4-8NPT	1.77	14.72	14.41	